

# Conduction cooling reaches new power heights

By Ivan Straznicky



*Power dissipation from rugged circuit cards continues to rise, calling into question how long incumbent card cooling approaches, like conduction, will last. Recent advances show that 160+ W can be conduction cooled at 85 °C card edge temperature. The setting of this new bar, and ongoing progress, attest to the staying power of conduction cooling, as it continues to meet the demanding requirements of advanced military electronic systems.*

The thermal packaging approach of choice for circuit cards on many rugged military embedded systems is conduction cooling. This method provides inherent advantages including shock and vibration protection, the ability to house circuit cards in sealed chassis, and passive cooling. However, the conduction approach's cooling limits were considered a drawback several years ago because they were too low for advanced electronics and did not provide enough cooling headroom.

Limits of 50-60 W were once claimed to be ceilings for conduction cooling, with 100 W as a more recently assumed limit. In addition, the thermal contact resistance between conduction card edge and chassis rail was viewed as conduction's "Achilles' heel" because of the large relative temperature delta it created along the heat removal path.

During the past several years, these shortcomings have been the focus of significant research, analysis, design, and testing activity.

The results of this work have steadily advanced conduction-cooling capability, with the outcome that conduction cooling is now much more attractive for current *and* future electronics. New designs are now capable of cooling over 160 W (at 85 °C card edge). Some of the advances that have made this possible are: embedded heat pipes, new thermal interface materials, emerging standards such as VPX-REDI, thermal contact resistance reduction, and chassis-level liquid cooling.

### Embedded heat pipes

A recent advance in conduction cooling is the use of embedded heat pipes in conduction frames. Heat pipes are thermally interesting because they can move large amounts of heat with very little temperature difference, with no input power requirement, and no moving parts. Heat pipes have been used for cooling since the 1960s, with early use focused on space applications because of both the aforementioned benefits and their ability

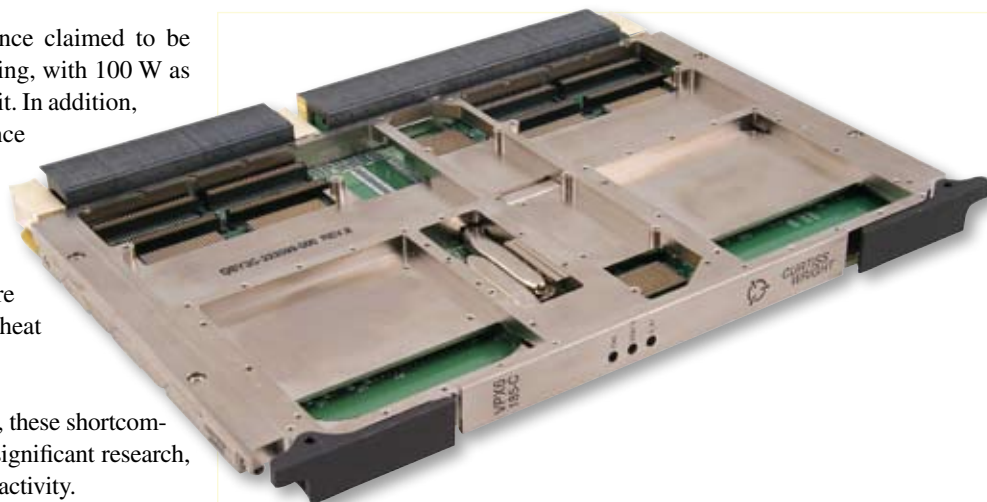

Figure 1

to work in microgravity environments. Since their introduction, the use of heat pipes has greatly increased, particularly for terrestrial commercial electronics cooling where the gravity-dependence of heat pipes is not a drawback. Another attraction of heat pipes is their relatively low cost compared to other high-power cooling solutions.

Heat pipe use in rugged military environments poses several challenges, such as orientation-dependence, shock and vibration, acceleration limitations, and cold start-up. Curtiss-Wright Controls Embedded Computing has been researching and testing heat pipe use in harsh environments. This work has led to CWCEC's patented design of an embedded heat pipe frame that successfully meets these challenges. The highly engineered design will be used for advanced processors that cannot be cooled with typical conduction approaches, such as the VPX-185 single board computer shown in Figure 1.

### Thermal Interface Materials

Conduction-cooling design is also benefiting from a greater understanding of Thermal Interface Materials (TIMs). TIMs are used between mating conduction surfaces along the heat removal path and have been an essential part of conduction cooling for many years now. With the increased power dissipation and densities of recent processors, TIMs have become even more important. Not coincidentally, TIM manufacturers have introduced a steady stream of improved products that attempt to keep up with the power increases. These products include: gap pads, thermal putties, thermal adhesives, Phase Change Materials (PCMs), filled gels, and even solders. Figure 2 shows typical thermal resistances associated with use of these materials[1].

A key characteristic of any TIM is its thermal conductivity, or the application-dependent inverse, thermal resistance. Thermal conductivity values are published by vendors for use in thermal analyses like Finite Element Analysis (FEA). Years of testing, however, have shown that these values are consistently higher than independently measured figures. Large discrepancies are not uncommon, for example, in one case the measured value was less than 10 percent of the published value. Using the published value in a thermal analysis would have caused a substantial under-prediction in junction temperature, greatly increasing the risk of thermal failure. As more and more "new and improved" TIMs come to market, testing for thermal conductivity (and other material properties) is essential to separate the winners from the losers.

### VPX-REDI (aka VITA 48)

New open standards are also helping to foster conduction-cooling improvements. VITA 48.2 is standardizing mechanical formats that are compatible with IEEE 1101.2 card slots. It also allows for increased functional density and thermal management with a 1" pitch (the IEEE 1101.2 pitch is 0.8"). The increased pitch, along with other changes, offers cooling improvements that extend conduction cooling to higher allowable powers.

### Card edge thermal contact resistance

Thermal contact resistance is another field where increased research has helped improve conduction-cooling design. When two surfaces in contact have heat flowing across their junction, a measurable temperature difference arises caused by contact resistance. This thermal resistance is because surfaces are not perfectly smooth at the microscopic level (see Figure 3 for a schematic view of the interface); thus, only a few points of actual contact are made with the rest of the area consisting of air gaps. In the absence of a TIM (that is, a conduction-card edge and chassis rail), the air's low thermal conductivity creates a substantial thermal resistance between mated surfaces. The value of this resistance is a complex combination of factors including surface finish, hardness, flatness, and apparent and actual contact area and pressure.

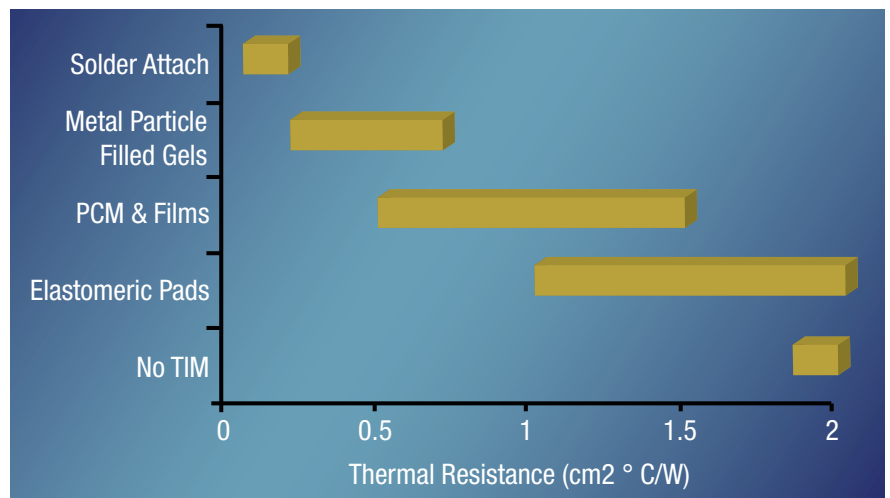

Figure 2

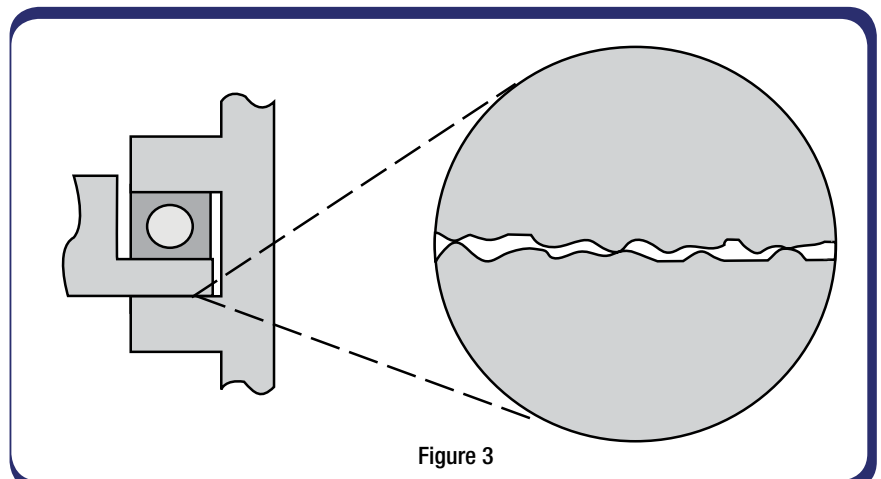

Figure 3

In the case of a typical IEEE 1101.2 conduction-card edge mated to a chassis rail, the contact resistance value used by many thermal engineers is in the range of 0.3 to 0.5 °C/W. As a result of several initiatives and based on test data, significantly lower contact resistance values have been achieved, as low as 0.1 °C/W. This reduction in thermal resistance enables the chassis rail, and more importantly its cooling medium, to be at a higher temperature for the same amount of card power dissipation and results in more efficient cooling.

### Chassis cooling

While heat pipes, TIMs, VPX-REDI, and contact resistance have all improved conduction-cooling design at the card level, significant advances such as liquid cooling are also being made at the chassis level. With it now possible to cool 160+ W at the card level per slot, chassis cooling presents itself as a potential limitation. The typical chassis-level approaches of natural convection, forced air, or conduction will not be able to cool heat loads with even just a few of these powerful cards.

Fortunately, new chassis designs are being introduced that can cool significantly more heat than previous generations. Many of these designs use liquid in the sidewalls (see Figure 4, photo courtesy of Hybricon) because of inherently superior thermal properties compared to air, for example, thermal conductivity, density, and specific heat. The liquid can be supplied by the platform's Environmental Control System (ECS), or some designs have optional integrated heat exchangers to cool the warmed liquid. These and other innovative chassis designs are advertising the ability to cool conduction cards of 100-200 W, making them compatible with the new generation of high-functional-density cards.

### The conduction cooling outlook

The aforementioned advances continue to push the limits of conduction-cooling capability. However, diminishing returns are being seen even with increased effort in thermal research, analysis, design, and testing. Fortunately, processor power dissipations will reach a plateau in the near term, with more efficient architectures and transistor material advances. This will allow the state of the art in conduction cooling to advance further and continue to meet many rugged military system requirements.✦



*Ivan Straznicky is a senior staff mechanical engineer for Curtiss-Wright Controls Embedded Computing. He has 18 years of manufacturing and mechanical engineering and management experience in the military and aerospace industry. His responsibilities include advanced thermal and packaging technologies for the company's products. Ivan has a degree in Mechanical Engineering from McGill University in Montreal, Canada. He can be contacted at [ivan.straznicky@curtisswright.com](mailto:ivan.straznicky@curtisswright.com).*

### Curtiss-Wright Controls Embedded Computing

613-599-9199

[www.cwcembedded.com](http://www.cwcembedded.com)

### References:

1. *ElectronicsCooling*, Vol. 11, No. 4, November 2005.



Figure 4